

TO: CITY MANAGER

2003 September 30

FROM: DIRECTOR PLANNING AND BUILDING

SUBJECT: **BURNABY INFORMATION KIOSK**
Proposed Relocation and New Design - Metropolis at Metrotown
X-Ref. Rezoning Reference #02-27

PURPOSE: To provide information regarding the proposed relocation and redesign of the Burnaby Information Kiosk within Metropolis at Metrotown.

RECOMMENDATION:

1. **THAT** Council approve the Burnaby Information Kiosk proposal as outlined in this report.

R E P O R T

1.0 SUMMARY

This report refers to the proposed relocation, redesign and installation of the Burnaby Information Kiosk that is currently located in the above-grade pedestrian walkway that connects the Metrotown Centre and the Metropolis shopping centres. Relocation of the kiosk (to be funded entirely by the developer) is included in the current proposal to renovate and expand the two shopping centres under Rezoning Reference #02-27 into a single integrated shopping complex. The relocated kiosk was described in the report advancing the rezoning to a Public Hearing. Rezoning for Phase I has been adopted and rezoning for Phase II is being pursued to completion in the next few months. The proposed relocation and design of this kiosk as part of Phase II and as outlined in this report is considered supportable and will continue to meet the City's needs as a community resource. This matter would normally be considered by the Finance and Civic Development Committee which provides overall guidance to the City's various civic facilities and economic initiatives, including tourism. However, the next regular Committee meeting is not until 2003 October 23 and the rezoning application requires that the design and documentation of the new information kiosk be finalized in the next few weeks. Staff discussed this situation with the Chair of the Committee who has agreed to forward this report directly to Council so that any delay of the rezoning application is avoided.

2.0 BACKGROUND

- 2.1 The existing Burnaby Information Kiosk was installed in 1988 by the Metrotown Centre shopping centre as part of their expansion proposal at that time. It is located on the south side of the above-grade pedestrian walkway between the two shopping centres. The City is

responsible for the use and operation of the kiosk which has been used as community resource for various community groups and organizations on a first-come, first-serve basis. Since 1995 the kiosk has also been successfully used as a seasonal Burnaby Tourist Information Centre from May 01 through September 30, seven days a week. It is the intent of staff to examine the possible full-time use of this new facility given its new high profile location.

- 2.2 Ivanhoe Cambridge, the shopping centre owners have made an application to rezone the mall properties (Rezoning Reference #02-27) in order to renovate and expand the shopping centres on a phased basis. Phase I which involves the relocation of the main food court from Metropolis to Metrotown Centre and construction of a related underground loading area is now underway and Phase II which involves the construction of a new two level retail connection between the two shopping centres, additional outdoor plaza development and adjustments to the parking areas and driveways will commence in the near future.

3.0 GENERAL DISCUSSION

- 3.1 Phase I renovation of the shopping centres involves the development of a new high amenity and focal point food court on the second level of the Metrotown Centre portion of the complex near the Bay Department store. This new updated food court will replace the existing food courts on the lower levels of the two shopping centres which will be redefined and become part of the lower level retail areas as part of Phase II. The Phase II retail connection component will include approximately 4,669m² (50,263 sq. ft.) of new retail floor space on two levels which will replace and expand the existing pedestrian bridge.
- 3.2 The Burnaby Information Kiosk, a Phase II component, is proposed to be relocated and installed by the rezoning applicant as a stand alone facility on the upper level of the Metrotown Centre, west of the relocated food court and east of the elevators located within the atrium area (see **attached** Sketch #1). Situated in the central portion of the pedestrian mall, this location will be highly visible to the general public and in a high traffic area, exposed to a large volume of mall customers who will be drawn to the nearby main food court and the Bay department store located further to the east. The maintenance of the kiosk will be provided by the shopping centre and its use and operation will continue to be provided exclusively by the City, similar to the current situation which includes use by community groups as a resource centre and as a Burnaby Tourist Information Centre during specific periods. A Section 219 Covenant will be registered to ensure the City's control over the use and operation and the shopping centre's maintenance of the facility.
- 3.3 The applicant has prepared a design for the proposed facility which is illustrated on the **attached** Sketches #2 and #3). The new location and general design of the kiosk is an integral component of the suitable plan of development for the subject rezoning application which has been considered by City Council and submitted to a Public Hearing. The proposed

kiosk will be freestanding and oval in shape with overall dimensions of 4.5m (15 ft.) in length, 3.6m (12 ft.) in width. A customer counter at 1.1m (3ft 8 inches) above the floor will be provided around the perimeter of the kiosk and the interior will accommodate up to three persons with movable chairs. A portion of the customer counter will be designed to serve persons with disabilities. Multi-tiered brochure displays racks will be provided around the exterior of the kiosk which will have locking roll tops covers to secure and conceal the racks when the kiosk is closed. A glass display case will also be built into the customer counter to feature items of interest and/or for sale. Staff desk space will be provided along with lockable storage cupboards and drawers, electric, telephone and computer outlets. A 2.7m (9 ft.) high circular sign element will be provided at one end of the facility that will be used as a visual identification feature. Illuminated Burnaby logos and other identification signs will be prominently displayed on the exterior of the kiosk. The overall design, colors and materials will be consistent with the new interior design scheme for the shopping centre.

4.0 CONCLUSION

The proposed design and relocation of the Burnaby Information Kiosk as outlined above is supported by staff and is considered to provide an appropriate design and location to meet the needs of the City as a community resource facility and for the promotion of the local tourist industry. Consideration of the detailed location and design of the facility by Council is warranted at this time, so that the design of the facility can be finalized as part of the rezoning approval process and, subsequently, its construction pursued.



J.S. Belhouse
Director Planning and Building

PS:gk
Attach

cc. Director Finance
Director Engineering
Director Parks, Recreation and Cultural Services
City Clerk

THE BAY

Mall Level 2

Relocated Foodcourt

Proposed Relocated
Burnaby Kiosk

EXISTING PARKADE

NOTE:
THE NEW FOODCOURT WILL BE FULLY
OPERATIONAL PRIOR TO THE
DEMOGRAPHING OF THE EXISTING
METROPOIS FOODCOURT.
THE PROPOSED TOURIST INFO KIOSK
WILL BE COMPLETED AND OPERATIONAL
PRIOR TO THE DEMOLITION OF THE
EXISTING KIOSK AT THE LOW BRIDGE.
FOODCOURT LAYOUT AND DIMENSIONS
ARE FOR ILLUSTRATIVE PURPOSES
ONLY.

PROPOSED SOUTH
ENTRANCE RENOVATION

Sketch 1

Proposed Relocated Burnaby Information Kiosk

September 8, 2003

Rezoning Reference # 02-27

INTERNALLY LIT CITY OF
BURNABY LOGO

4" HIGH ALUMINUM RING
WITH 8" HIGH METAL LETTERS

INTERNALLY LIT INFORMATION
SIGN WITH CHANGEABLE
GRAPHIC PANEL

LIGHT ELEMENT

*NOTE: ALL LIT ELEMENTS CAN
BE TURNED OFF WHEN NOT IN
USE.

WORK AREA FOR 2 PEOPLE

INTERNALLY CITY OF BURNABY
LOGO

ACCESSIBLE SERVICE AREA

ENTRY GATE AND OPTIONAL ACCESSIBLE
SERVICE AREA

3 TIER LOCKABLE BROCHURE DISPLAY

CITY OF BURNABY MERCHANDISE DISPLAY
CASE

3 TIER LOCKABLE BROCHURE DISPLAY

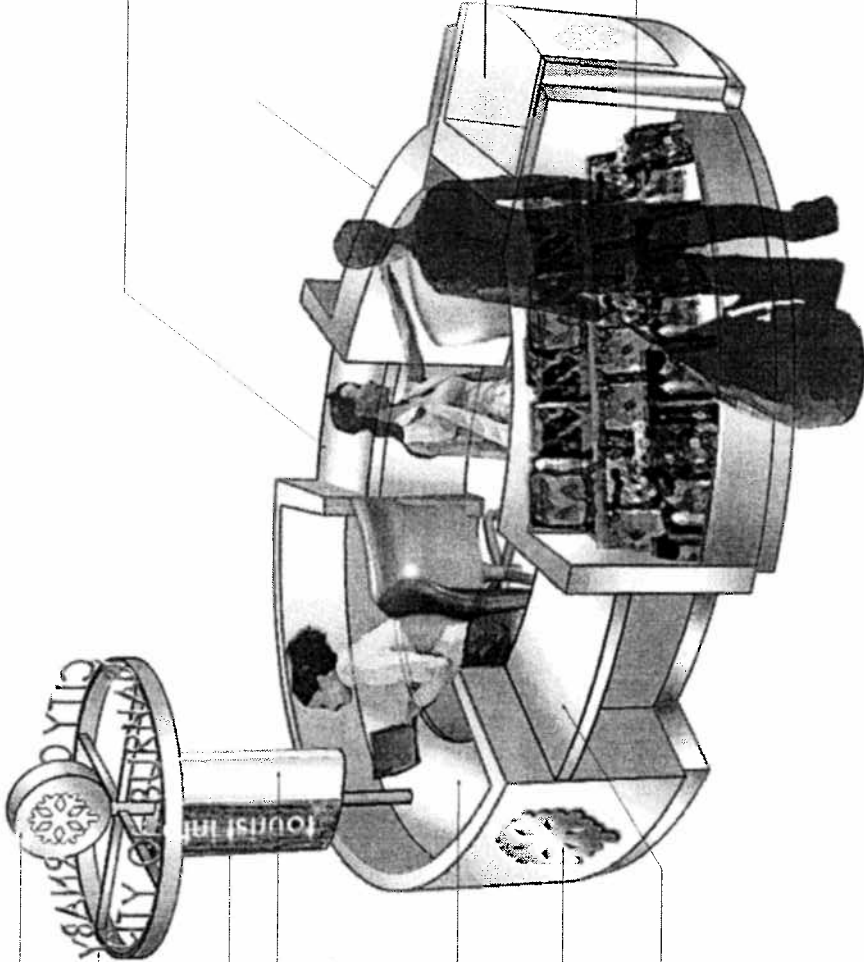

CITY OF BURNABY INFORMATION KIOSK

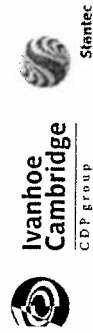

METROPOLIS AT METROTOWN
September, 2003

Sketch 2

Proposed Relocated Burnaby Information Kiosk

zoning Reference # 02-27

September 8, 2003

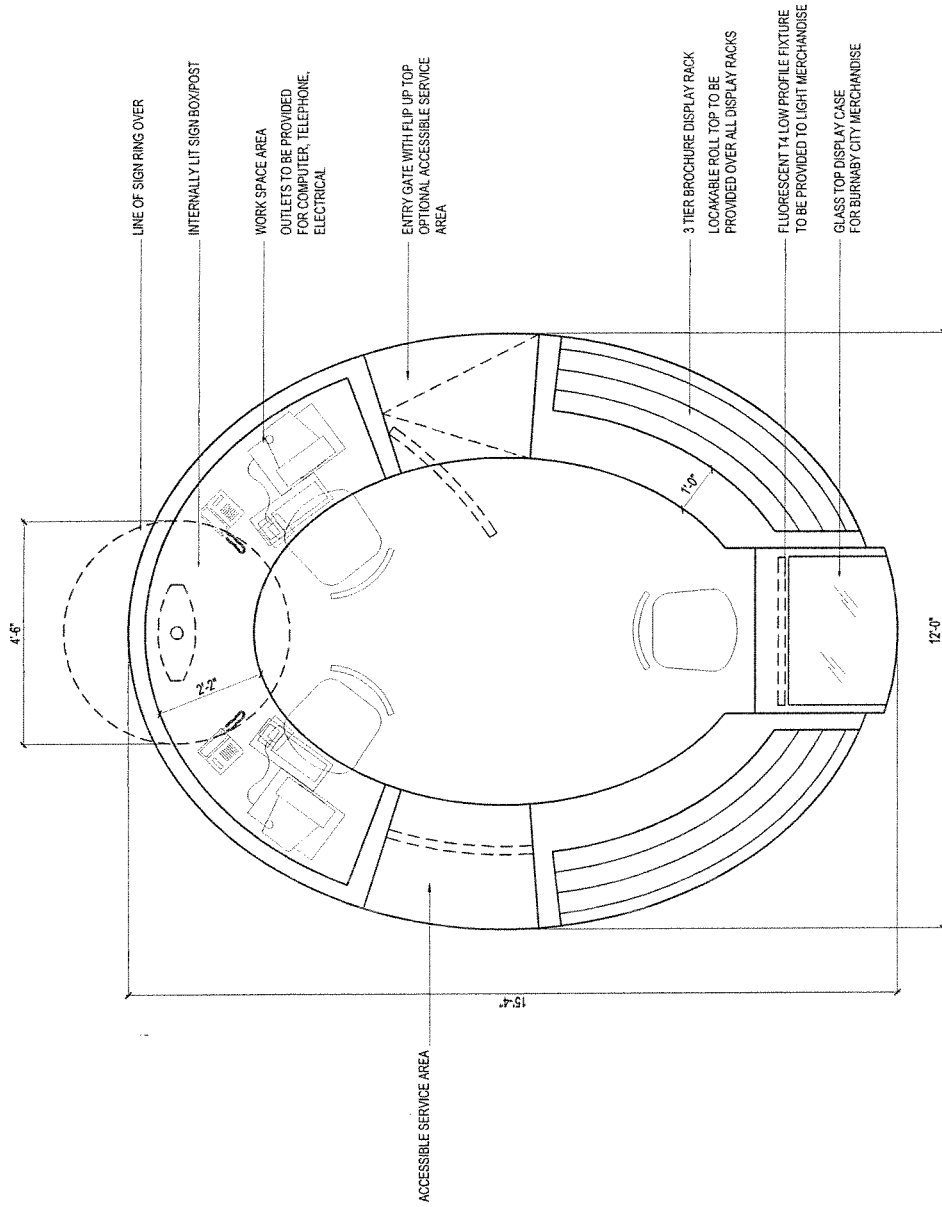

CITY OF BURNABY INFORMATION KIOSK

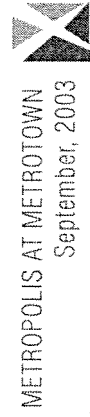
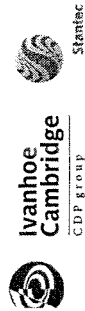

Sketch 3

Proposed Relocated Burnaby Information Kiosk

Rezoning Reference # 02-27

September 8, 2003