

REPORT
Regular Council Meeting
1989 September 05

THE CORPORATION OF THE DISTRICT OF BURNABY

TRANSPORTATION COMMITTEE

HIS WORSHIP, THE MAYOR
AND ALDERMEN

Madam/Gentlemen:

REPORT OF THE TRANSPORTATION COMMITTEE

RE: TRANSIT PLANNING PROCESS AND
1990/91 ANNUAL SERVICE PLAN

RECOMMENDATION:

1. THAT Council approve the Transit Planning Process outlined in the attached report.
2. THAT Council approve the review process for the 1990/91 Annual Service Plan as outlined in the attached report.

R E P O R T

Council, at the regular Council meeting held on 1989 August 08 received the draft 1990/91 Annual Service Plan for the Vancouver Regional Transit System and referred same to the Transportation Committee with a request to develop a review process for transit issues in general and, more specifically, the 1990/91 Annual Service Plan.

The Transportation Committee adopted the process for consideration of the 1990/91 Annual Service Plan as outlined in the attached report and in addition requested Mayor Copeland respond to Mayor Lanskill, Chairman of the Vancouver Regional Transit Commission, advising of the process associated with the 1990/91 Service Plan review and of the additional time required to complete the review.

The Transportation Committee therefore requests Council's approval of the transit planning process as outlined in the attached report. A copy of Mayor Copeland's correspondence is also included for Council's information.

Respectfully submitted,

Alderman R.G. Begin
Chairman

Alderman D.P. Drummond
Member

Alderman J.M. Sawicki
Member

INTERNAL DISTRIBUTION:
AGENDA 1989 SEPTEMBER 05
COPY - MUNICIPAL MANAGER
- DIRECTOR ENGINEERING
- DIR. PL. & BLDG. INSP.

TO: CHAIRMAN AND MEMBERS
TRANSPORTATION COMMITTEE

1989 August 29

FROM: DIRECTOR PLANNING &
BUILDING INSPECTION

Our File: 08.211

SUBJECT: TRANSIT PLANNING PROCESS

PURPOSE: To seek Committee approval of a process to address transit issues in the Municipality and accommodate a review of the draft 1990/91 Annual Service Plan.

RECOMMENDATION:

1. THAT the Transportation Committee recommend that Council approve the transit planning process outlined in this report.
2. THAT the Transportation Committee recommend that Council approve the process for consideration of the 1990/91 Annual Service Plan as outlined in this report.

R E P O R T

1.0 BACKGROUND

During consideration of the North Burnaby Transit Area Plan on 1989 May 29, Council noted the lack of response by BC Transit to outstanding issues previously raised by Council. To address this concern it was noted that there was a need to develop a more clearly defined and responsive process for dealing with transit issues in the Municipality.

A revised process for planning transit in the Municipality would aim to promote more effective communication between the Municipality, BC Transit and the public. It appeared that achieving this objective required a process which provided a forum for less formal but more detailed discussion of transit issues between Council members, BC Transit staff and the public. This report outlines a process which would involve the Transportation Committee of Council as an appropriate forum for the consideration of transit matters. At the same time it outlines a process for immediate consideration of the draft 1990/91 Annual Service Plan.

2.0 CURRENT ROLE OF THE MUNICIPALITY

Direct responsibility for the planning and operation of transit services rests with BC Transit. With regard to the provision of transit within Burnaby however, the Municipality exercises two primary functions including:

(i) Review of BC Transit Plans

Transit plans developed by BC Transit can include the following:

- minor service changes
- annual service plans
- area plans
- operations plans
- rapid transit plans
- policy plans
- long range plans

Currently the Municipality exercises a review function but generally does not participate directly in the initial development of these plans.

(ii) Public Input on Transit

The Municipality also deals directly with residents of Burnaby with regard to existing and planned transit service. Public input can be derived from the following sources:

- correspondence to Council
- delegations at Council meetings
- public meetings or open houses on transit

Currently public concerns regarding transit service are usually referred to BC Transit for comment.

The current role of the Municipality is therefore essentially one of reacting to plans and proposals generated from either BC Transit or the general public.

The following sections outline a revised process to undertake these two functions and also adopt a more proactive approach to transit planning within the Municipality.

3.0 PROPOSED TRANSIT PLANNING PROCESS

3.1 Objectives for a Revised Process

The revised transit planning process is intended to achieve the following objectives:

- (i) to provide opportunities for less formal, more detailed discussion of transit matters
- (ii) to establish a forum for involvement of Council members, BC Transit staff and the public in the resolution of transit issues
- (iii) to adopt a more proactive approach by the Municipality in planning transit services in Burnaby.

The following sections outline a revised process to undertake the two current functions of reviewing BC Transit plans and receiving public input on transit. It also incorporates a more proactive approach to generate municipal proposals for transit service improvements.

3.2 Review of BC Transit Plans

The process for review of BC Transit plans noted in the previous section will vary depending on the type and scale of the plan under consideration. The proposed process for each of these plans is outlined in the following:

3.2.1 Minor Service Changes

(i) Description

Minor service changes which involve use of municipal streets previously not used by transit would require municipal approval. Generally these consist of reroutings of existing bus services. Review of these service changes by the Municipality, if required, usually occurs some months prior to their implementation on a Quarterly basis in September, December, April or June.

(ii) Current Process

Minor service changes proposed by BC Transit are currently routed directly to Council and referred to staff for a report and subsequent review and approval by Council.

(iii) Proposed Process

It is proposed that minor service changes could be given more detailed consideration by the Transportation Committee and should therefore be referred by Council to the Transportation Committee for review. Public input would be accommodated through delegations received by the Committee. BC Transit staff could also be available to address specific concerns. The Transportation Committee would then report back to Council with a recommendation.

3.2.2 Annual Service Plan

(i) Description

The purpose of the Annual Service Plan (ASP) is to define region-wide service improvements to meet transit demand for the forthcoming BC Transit fiscal year from April 01 of one year to March 31 of the succeeding year. Included in the service plan are preliminary route descriptions, service levels, vehicle requirements, hours of service, costs of service and ridership estimates.

(ii) Current Process

Under the current process, review of the Annual Service Plan is initiated by receipt of a letter from BC Transit asking for a list of the Municipality's requests for transit service. Responses are prepared by staff then reviewed and endorsed by Council and forwarded to BC Transit for inclusion in the preliminary Annual Service Plan. After review by the Vancouver Regional Transit Commission, the draft service plan is forwarded to Councils for comment and presented at Public Open Houses held throughout the Vancouver Region. The final Annual Service Plan is then developed after receipt of Councils' comments and public input. On approval of the final report, the Annual Service Plan is used to formulate the BC Transit budget request from the Provincial Government for the fiscal year.

In the case of the 1990/91 Annual Service Plan this process has been somewhat compressed with Council receiving the draft Annual Service Plan just over one month before BC Transit's deadline of 1989 September 13 for receipt of Municipal comments.

(iii) Proposed Process

In considering the 1990/91 Annual Service Plan the process as outlined below will be followed. As shown in Figure 1, a revised process for review of Annual Service Plans would involve the Transportation Committee in the formulation of the Municipality's requests for transit service for inclusion in the Annual Service Plan. Upon approval by the Transportation Committee, these would be submitted to Council for approval then forwarded to BC Transit for inclusion in the preliminary Annual Service Plan.

Upon receipt of the preliminary Annual Service Plan from BC Transit, Council could refer the plan to the Transportation Committee for detailed review. The Transportation Committee would review the Plan in conjunction with BC Transit and municipal staff and forward comments to Council. Also available for consideration by the Transportation Committee would be public comments on the Plan derived from Public Open Houses held by BC Transit.

A representative of BC Transit would be requested to attend Transportation Committee meetings to help provide technical assistance when discussing the annual service plan. BC Transit is agreeable to participating with the Committee.

(iv) Six Month Service Review

Major service changes such as those implemented in a Transit Area Plan or Annual Service Plan are subject to a review after six months. This review includes an analysis of user complaints and operational problems with the service changes.

The Six Month Service Review provides a key opportunity for the Municipality to communicate to BC Transit any concerns with respect to the North Burnaby services which have arisen from monitoring the service changes. It is proposed that a report be prepared for consideration for the Transportation Committee with input from BC Transit staff. Recommendations could then come forward from the Transportation Committee for Council consideration and subsequent submission to the Vancouver Regional Transit Commission.

3.2.3 Area Plans

(i) Description

The purpose of a transit area plan is to review the current transit system in an area of the Greater Vancouver Region and determine whether transit is adequately meeting current and future transportation needs of the area. An area plan defines a series of transit planning objectives and policies and specific improvements to transit service. Area plans cover a period of three years with the service changes implemented through three successive annual service plans over the period.

(ii) Current Process

Involvement of the Municipality in the area planning process is initiated with the development of a draft area plan by BC Transit which is submitted to Council and subsequently referred to staff for a report. Prior to submitting a report to Council, changes in bus routes are introduced by BC Transit to staff through a bus tour. Public input to the area plan is received through Open Houses conducted by BC Transit. Council then received a report on the area plan reflecting both the operations review and public input.

(iii) Proposed Process

As shown in Figure 1, the revised process for dealing with area plans would begin with the submission by BC Transit of a draft area plan to Council. Council could then refer the report to the Transportation Committee. The Committee's review of the area plan would consist of two parts, a planning review and an operational review. The planning review would provide an evaluation of the area plan from a service perspective; the operational review would focus on the operational feasibility of the proposed bus routes relative to the Burnaby street system.

The Transportation Committee could also participate in Open Houses held to receive municipal public input on the Transit Area Plan. Public comments on the Transit Area Plan would be incorporated into the planning review.

The accompanying staff report to the Transportation Committee could consist of a number of issue papers to focus discussion. A representative of BC Transit would also be requested to attend Transportation Committee meetings when discussing area plans. Meetings would be open to the public and delegations would be welcomed. The results of these discussions would then be summarized in a report to Council together with recommendations.

3.2.4 Operations Plans

(i) Description

Area plans and service plans for the transit system are implemented through operations plans. Operations plans identify the specific measures required to implement a transit service or develop a transit facility. Operations plans can consist of the following types:

- transit facility plans - detailed plans for transit exchanges or park-ride facilities are usually reviewed by the Municipality through the established development permit process.
- bus priority measures - these plans outline changes to the road system required to reduce delay for transit vehicles due to traffic congestion. Bus priority measures include "queue jumpers" (i.e. separate lanes for buses to bypass traffic queues), traffic signal pre-emption measures and bus lanes.

(ii) Current Process

Proposals for service improvements identified in Annual Service Plans and Area Plans are often implemented through a specific operations plan. The Loughheed Mall Transit Exchange is an example of a project explicitly identified in the Transit Area Plan for North Burnaby and implemented through a separate process involving discussions between BC Transit, the Municipality and the developers of Brentwood Mall.

Previously operations plans have often proceeded independently of the review process for area plans and service plans. To avoid a situation where implementation could proceed ahead of Council approval, coordination between approval of the overall plan and the implementation process for an operations plan is required.

(iii) Proposed Process

It is suggested that all transit operations plans which are derived from proposals in a service plan or area plan be considered by the Transportation Committee in conjunction with review of the overall plan. Approval of the overall plan, i.e. area plan or service plan, will be required to implement a specific operations plan.

Operations plans which are independent of an overall plan could be reviewed separately by the Transportation Committee.

In both cases final approval by Council will be required.

3.2.5 Other BC Transit Plans

Longer range BC Transit plans come forward for municipal review at irregular intervals. Plans in this category may include the following:

- (i) rapid transit plans - studies of SkyTrain extensions (i.e. routes, stations, costs) and other transit technologies; preliminary designs for rapid transit
- (ii) policy plans - often involves plans for changes to the fare system
- (iii) long range plans - transit plans with a time horizon of more than three years including the proposed five year service plan.

It is expected that these plans would come to Council and be referred to the Transportation Committee for detailed review in conjunction with BC Transit staff. Public involvement, including delegations, information meetings, etc., would be accommodated at this stage. Recommendations would then come forward from the Transportation Committee for Council consideration.

3.2.6 Timing of Municipal Review of BC Transit Plans

It is anticipated that full consideration of BC Transit plans (eg. Transit Area Plans and the Annual Service Plan) by the Transportation Committee may require as many as three meetings. The first meeting would focus on a presentation by BC Transit on the Annual Service Plan and comments from the Transportation Committee. The second meeting would be concerned with a staff report on the Annual Service Plan and its implications for Burnaby. At the final meeting the Transportation Committee would provide comments to Council on the Annual Service Plan and recommendations regarding municipal requests for transit service to be submitted to the Vancouver Regional Transit Commission.

The process for consideration of BC Transit plans by the Transportation Committee is expected to occupy more time than required in previous years, possibly up to four months. BC Transit should therefore be requested to submit Transit Area Plans and Annual Service Plans for municipal comment sufficiently in advance of their deadlines to allow for full consideration by the Transportation Committee. In the case of Transit Area Plans, Council approval of the Area Plan in concept will be required significantly in advance of consideration by the Municipality of implementation through an Annual Service Plan or Quarterly Service Adjustments.

3.3 Public Input on Transit

Correspondence and delegations are the primary means for direct public input to Council on transit matters. Public input usually relates to existing transit service or a BC Transit plan for future services. Procedures for handling public input are outlined in the following sections.

3.3.1 Correspondence to Council

Council receives correspondence on transit matters directly which are usually referred to BC Transit for a response. This procedure should be retained as BC Transit, not the Municipality, should respond directly to concerns about the transit system. The Transportation Committee through municipal staff would monitor correspondence and replies to ensure an expeditious response. BC Transit should be requested to agree to this approach.

3.3.2 Delegations on Transit

Delegations appear before Council to provide public input during consideration of specific transit matters such as a Transit Area Plan, Annual Service Plan or minor bus rerouting. In instances where a delegation to Council raises an issue separate from these plans, the matter could be referred for consideration by the Transportation Committee and the preparation of a recommendation for submission to Council. The Transportation Committee could receive delegations and hold meetings as necessary to review transit plans or hear public input on transit issues.

3.4 Municipally Generated Transit Proposals

Up to this point, the revised transit planning process has emphasized improving the current role of the Municipality in processing plans and proposals generated by BC Transit and the public. The Municipality however, can also adopt a more proactive stance in generating plans and proposals for service improvements. The following outlines some of the sources where municipally-generated proposals could arise.

- (i) public suggestions - suggestions of particular merit generated by the public could be pursued directly with BC Transit including correspondence and delegations to Council and Open Houses conducted in the context of an Area Plan or Service Plan.
- (ii) ASP municipal requests - the Municipality has the opportunity to submit "municipal requests" for transit service improvements to be included in the draft Annual Service Plan.
- (iii) discussion papers - transit issues of municipal and regional importance could be brought forward for consideration by the Transportation Committee in the form of discussion papers. Example topics could include rapid transit to Coquitlam, express bus service, the municipally-oriented transit system, etc.
- (iv) outstanding transit issues - a number of transit issues of importance to the Municipality as noted in a previous report to Council, remain unresolved. These include the fare zone boundary, trolley extensions, marketing programs, etc. It is proposed that the Transportation Committee provide the forum for detailed discussion of these issues with the direct involvement of BC Transit staff leading to a recommendation for the consideration of Council.
- (v) update of the Transportation Plan - the Comprehensive Transportation Plan is almost ten years old and will require updating to reflect current trends and developments including the Provincial Transportation Plan, SkyTrain, Metrotown, demographic changes, etc. The process of updating the Transportation Plan would require the intensive involvement by the Transportation Committee, the community and representatives of provincial agencies including the Ministry of Transportation and Highways and BC Transit prior to its adoption by the Municipal Council.

4.0 RELATIONSHIP TO THE 1990/91 BC TRANSIT ANNUAL SERVICE PLAN

The process for reviewing Annual Service Plans as outlined in this report is recommended to be followed in the case of the 1990/91 Annual Service Plan notwithstanding the deadline of 1989 September 13 imposed by BC Transit for receipt of municipal comments.

At its regular meeting of 1989 August 08, Council received correspondence from BC Transit requesting Council to review and comment on the following:

- (i) 1990/91 Annual Service Plan

The purpose of the Annual Service Plan is to outline a base level of service and to identify service changes for the fiscal year 1990-91 as a prerequisite to the development of a detailed operating budget. A final plan will be submitted to the Vancouver Regional Transit Commission at its meeting of 1989 October 05 following a series of public meetings held in early September.

(ii) Municipal Requests for Transit Service

The Annual Service Plan usually includes a list of requests for transit service from each of the Municipalities in the transit service area. The implications of the service change and the BC Transit response to each request is provided as an Appendix to the Annual Service Plan.

The municipal response is requested by 1989 September 13 for inclusion in the submission of the final Annual Service Plan to the Vancouver Regional Transit Commission. This timing however does not allow for adequate consideration of the Annual Service Plan by Council and the Transportation Committee according to the process outlined in this report.

During consideration of the North Burnaby Transit Area Plan on 1989 May 11 the Transportation Committee noted that there was insufficient time for detailed consideration of the report's content. They also advised Council that they:

"were interested in being given the opportunity to receive information on future phases of the North Burnaby Transit Area Plan and that a suitable time be allowed for the Committee to conduct a comprehensive review of same."

With respect to transit service in Burnaby the 1990/91 Annual Service Plan is almost exclusively concerned with implementation of Phase II of the North Burnaby Transit Area Plan. Therefore if the Transportation Committee and Council are to give full consideration to Phase II of the Transit Area Plan additional time will be required.

Recognizing this objective, the following process for review of the 1990/91 Annual Service Plan incorporating the following milestones is recommended:

- (i) September 06 Committee Meeting - a representative from BC Transit has agreed to attend to address comments and questions from the Committee.
- (ii) Mid-September Committee Meeting - the Committee will consider a staff report on the Annual Service Plan. The staff report will provide an evaluation of the Plan and its implications for Burnaby.
- (iii) September 19 Public Open House - this forum for public input on the Annual Service Plan conducted by BC Transit will be held at Bonsor Recreation Centre at 7:30 p.m.
- (iv) Early October meeting - the Committee will formulate comments to Council on the Annual Service Plan and recommendations regarding municipal requests for transit service. These comments will be based on the review of the staff report and the comments received from the public open house.

The recommendations could then be conveyed to the meeting of Council on 1989 October 16.

5.0 CONCLUSION

In a letter to the Chairman of the Vancouver Regional Transit Commission of 1989 May 26 Council noted as one of the conditions for approval of the North Burnaby Transit Area Plan the need "to develop a more responsive process to address transit issues in the Municipality." In consideration of the Transit Area Plan there was insufficient time for a thorough review as provided for under the revised planning process outlined in this report. Recognizing that Transit Area Plans provide a context for implementation of service changes through Annual Service Plans, Area Plans will be subjected to a more detailed assessment in the future.

The 1990/91 Annual Service Plan however, should be fully reviewed by the Transportation Committee even though a full review by the Transportation Committee will mean that the BC Transit deadline for receipt of comments will not be met. It is more important at this stage for Council to indicate their commitment to a process which will promote more intensive and participatory discussion of transit issues in the Municipality.

AMP
RG/mcb
Attachs:

A. L. Parr

A. L. Parr
DIRECTOR PLANNING &
BUILDING INSPECTION

cc: Municipal Manager
Acting Director Engineering

PROPOSED REVIEW PROCESS: ANNUAL SERVICE PLAN AND AREA PLANS

FIGURE 1

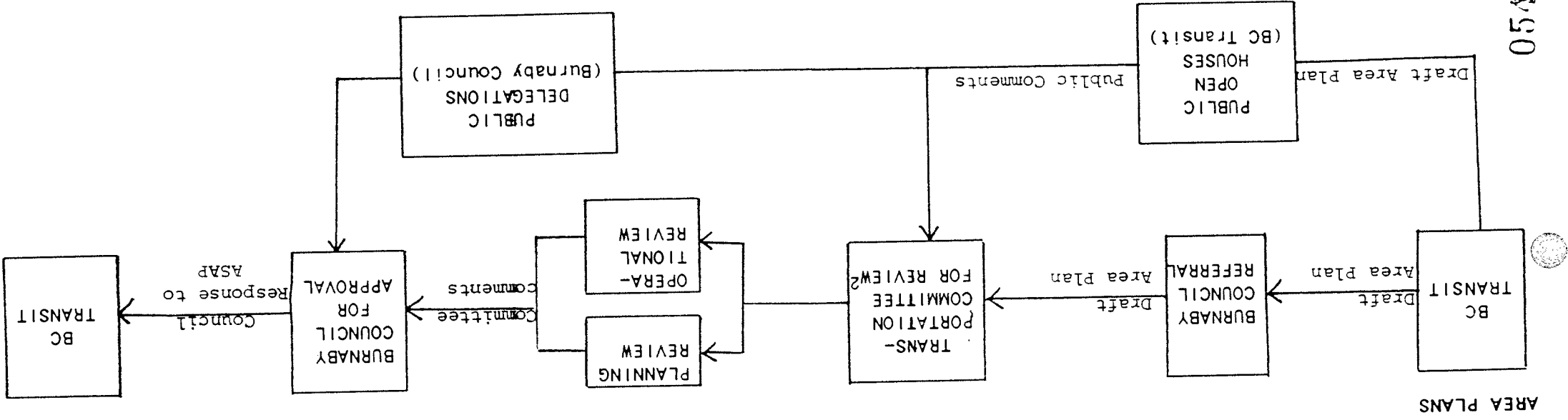
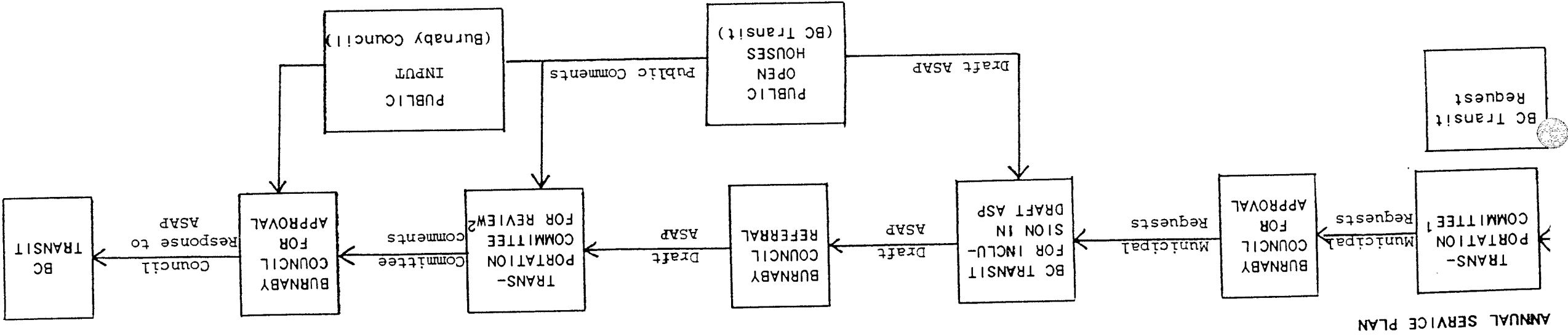

1. BC Transit would initiate this process by requesting submission of municipal requests
2. Includes BC Transit staff

26



OFFICE OF THE MAYOR

WILLIAM J COPELAND
MAYOR

40-19 CANADA WAY
BURNABY, BRITISH COLUMBIA V5G 1M2
TELEPHONE (604) 294 7340

1989 August 25

Mayor Don Lanskail
Chairman of the Vancouver
Regional Transit Commission
1200 West 73rd Avenue
Vancouver, B.C. V6P 6M2

Reference: 1990/91 Annual Service Plan for the
Vancouver Regional Transit System

Dear Mayor Lanskail:

Thank you for your letter dated 1989 August 18 in which you request that the Municipality of Burnaby review the Draft 1990/1991 Annual Service Plan for the Vancouver Regional Transit System and provide a response to BC Transit staff by 1989 September 13.

I wanted to take this opportunity to advise you that the Burnaby Transportation Committee has been requested by Council to develop a process that would help streamline the required municipal input within the overall transit planning process. The Committee, at its meeting of 1989 August 24, agreed on a general approach that will involve the Transportation Committee in transit planning matters. This approach is being recommended to Council, together with a further recommendation that BC Transit staff be requested to participate in those Committee deliberations.

With respect to the draft Annual Service Plan, the Committee has scheduled special meetings in September to review this Plan and its relationship to the North Burnaby Area Plan. It is anticipated that three meetings will be necessary to complete the review and prepare its recommendations to Council. As such, it will not be possible for the Municipality to respond to BC Transit staff by 1989 September 13. We will however make every effort to complete our review as quickly as possible.

Yours sincerely,

William J. Copeland
M A Y O R

cc: Chairman, Transportation Committee
Director Planning & Building Inspection

RC-



BC Transit

August 18, 1989

Mayor William Copeland
The District of Burnaby
4949 Canada Way
Burnaby, British Columbia
V5G 1M2

B. H.

Dear Mayor Copeland:

RECEIVED

AUG 22 1989

MAYOR'S OFFICE

Re: 1990/91 Annual Service Plan for the
Vancouver Regional Transit System

Sometime during the past couple of weeks your Municipal Clerk would have received a letter from BC Transit staff accompanied by a draft copy of the 1990/91 Annual Service Plan for the Vancouver Regional Transit System. This Plan identifies service changes proposed for the next fiscal year including new routes and changes to existing routes. The purpose in circulating the Plan to all municipalities within the regional system was to invite a review of its contents followed by whatever comments or suggestions are appropriate to the circumstances. In order to facilitate a review, a list of suggestions made by your Municipality over the last three years was also enclosed.

The Vancouver Regional Transit Commission has adopted a proactive policy toward transit improvements in a major effort to shift the commuter mix away from the automobile and towards transit. The recent announcement by the Premier and the Honourable Rita Johnston of substantial extensions to the transit system has also improved the prospects for a better future for public transportation. It is in light of these circumstances that Commission members have instructed me to write to each of the Mayors within the system and request your personal attention to this very important initiative. BC Transit staff would like to have the response of your Municipality on or before September 13, 1989.

Sincerely yours,

Mayor Don Lanskaill
Chairman of the
Vancouver Regional
Transit Commission

COPY - COUNCIL
- MAYOR
- DIR. PL. & BLDG. INSP.